

# WTC-C50

## For Liquid Chlorine

The WTC-C50 Vault is a full top access unit designed to house a 50-gallon drum of liquid chlorine for water treatment systems.

### Standard Features:

- Heavy-duty FRP enclosure.
- Structurally engineered and certified for in-ground installation.
- Valve assembly and metering pump.
- 2" floor drain.
- Lockable lid with lock-open arm, stainless steel lock hasp, and stainless steel hinge.

### Optional Features:

- Stainless steel floor door.

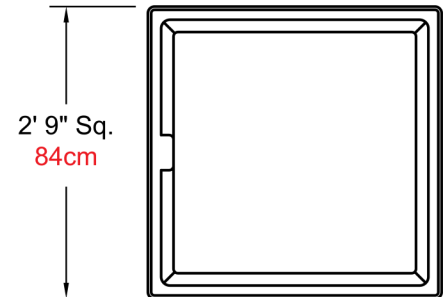
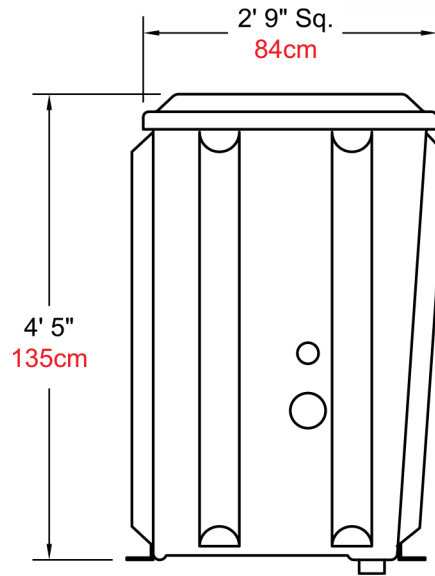

**WINAM CONSTRUCTION CORP**

www.winamgroup.com  
info@winamgroup.com

Catalog #	
Details	
Project	
Prepared by	
Date	