

# LNN-( )-ML(X)

Underwater or Dry, Niche Mounted  
20-75 Watts, 12 Volts

## Product Description:

The LNN Series 12 Volt fixture is a machined bronze light designed for energy consumption up to 75 Watts. This niche mounted light is UL listed for underwater or dry applications up to 50 watts. The 75 watt unit is UL Listed for underwater operation only.



## Detail:

Model Number	UL Max. Wattage Rating	Lamp Type	Watts	Volts	Lamp Life (Hours)
LNN-20-MLX	20	MR16	20	12	4000
LNN-35-MLX	35		35	12	4000
LNN-50-MLX	50		50	12	4000
LNN-75-ML	75		75	12	4000

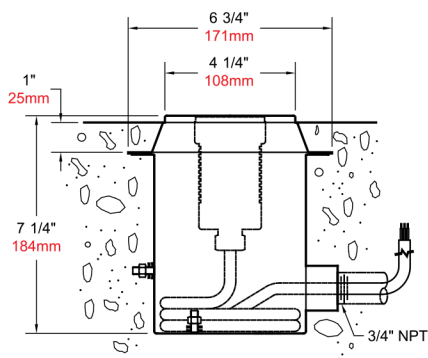

## Specification:

Fixture Body:	Machined brass with brass cord compression seal.
Wet Niche:	Stainless Steel with integral waterstop flange, grounding lug, and 3/4" conduit hub.
Cord:	Furnished with twenty feet of 16-3 Type STOW submersible cord.
Socket:	Bi-pin mount.
Gaskets:	High temperature, Vitor® O-ring.
Lens:	Clear, convex, high temperature tempered glass.
Lamp:	Per chart. Supplied separately, add suffix -LP to catalog number to include lamp.
Safety:	Units through 50 watt size are Underwriters Laboratories Listed for both underwater and dry application. 75 watt unit UL Listed for underwater application only.
Optional:	For stainless steel rock guard add suffix -RG to catalog number.
Optional:	Dichroic colored lenses - red, blue, green, amber, and turquoise available. Contact factory for custom colors.



**WINAM CONSTRUCTION CORP**

www.winamgroup.com  
info@winamgroup.com

Catalog #	
Details	
Project	
Prepared by	
Date	