

# D Vault

The versatile D Vault has been designed to offer a wider selection of recirculation pumps and filtration equipment and controls than our smaller vaults. Full top access to all equipment makes this unit east to adjust, maintain, or repair.

## Standard Features:

- Heavy-duty FRP enclosure with 2" floor drain.
- Structurally engineered and certified for in-ground installation.
- Thermally protected pumps.
- Forced air ventilation system.
- Lockable lid with lock-open arm, stainless steel lock hasp, and stainless steel hinge.
- Stainless steel anchors and tie-down cables.
- Wall mounted maintenance procedures for all equipment.

## Optional Features:

- Stainless steel floor door.
- Main pump strainers.
- Choice of 18", 24", or 30" sand filter with multi-port valve or 25 or 50 square foot cartridge filter with spare filter element.
- 'Pop-up' UL Listed control panel for full system control.
- Pressure and vacuum gauges.
- 3/4" water fill station with solenoid valve, water hammer arrestor, and hose bib with hose.
- 1" - 2" water fill station with solenoid valve, pressure reducing valve, water hammer arrestor, and hose bib with hose.
- Silver ion water treatment system.
- Ozonation systems.
- Low pressure shut-off.
- Automatic sump pump.

Not all options are available in certain vault configurations. For equipment specification data, or configuration and design assistance, contact us at (512)392-1155 or email us at design@fountainpeople.com.

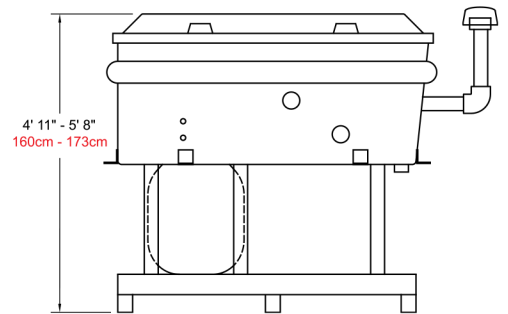
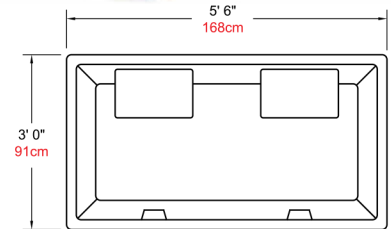

## Filter:

Pump HP	Type	Tank Size	Filter Rate (GPM)	Filter Rate (LPM)
1/2	Sand	18"	35	132
3/4	Sand	24"	63	238
1 1/2	Sand	30"	98	370
1/2	Cartridge	25SF	10	37
1/2	Cartridge	50SF	20	75

## Data:

Model Number	Main Pump HP	Max GPM @ 40' Head	Max LPM @ 1.2 Bar	Electrical
PFV-D300	3	3	624	120/240V, 1Ø, 60 Hz 120/208V, 3Ø, 60 Hz
PFV-D400	4	4	757	
PFV-D500	5	5	832	



**WINAM CONSTRUCTION CORP**

www.winamgroup.com  
info@winamgroup.com

Catalog #	
Details	
Project	
Prepared by	
Date	